

1. Install the ice maker properly in accordance with the instructions on location, water supply/drain connections and electrical connections stated in the instruction and installation manuals provided. Allow 10mm extra space at the installation site to meet any installation requirements (additional spacing is also required for proper air flow and pipe connections).
2. The ice production depends on the ambient and water temperatures. Refer to the instruction manual.
3. Product code: M035-C101, M035-C121

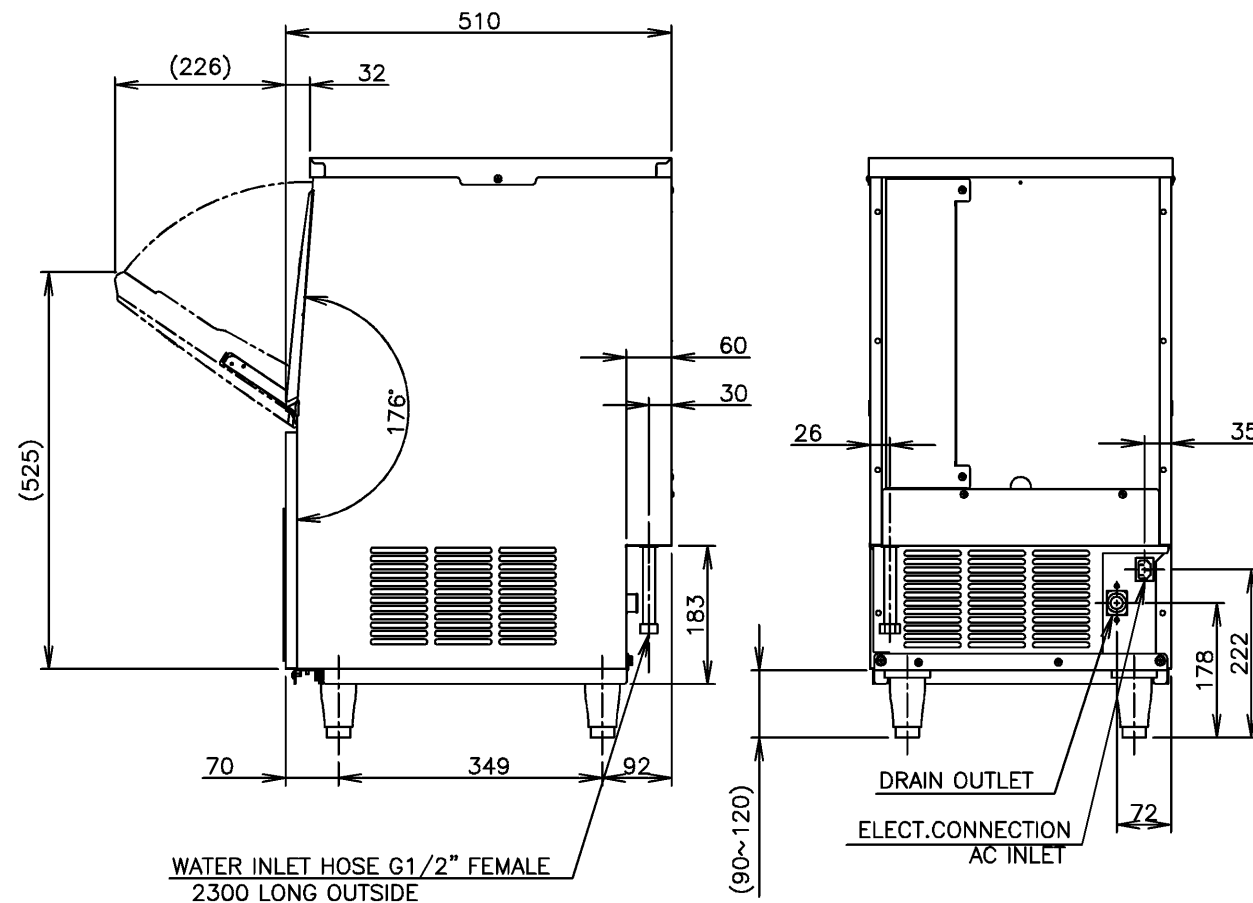
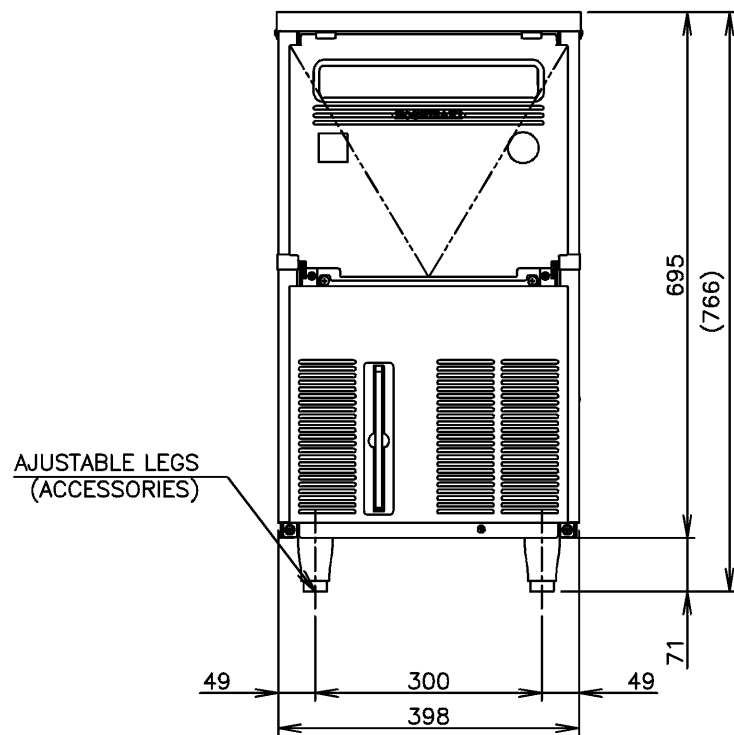
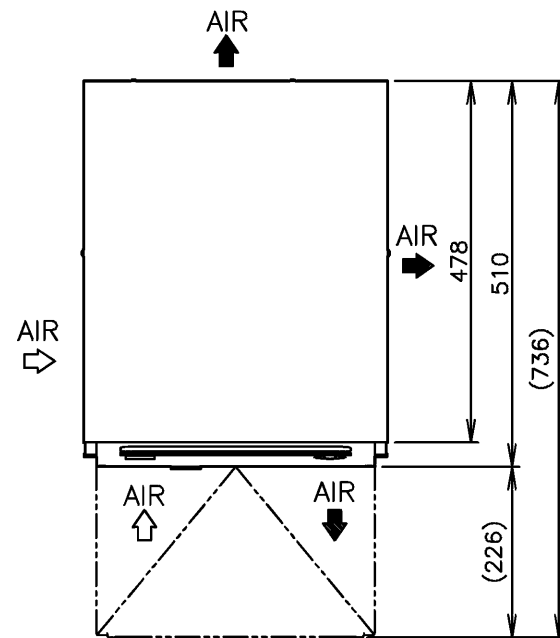

ITEM	Hoshizaki Cube Ice Maker	
MODEL	IM-30CA	
AC SUPPLY VOLTAGE	1 PHASE 220-240V 50Hz	
AMPERAGE	1.7A (AT.32°C, WT.21°C)	
STARTING AMPERAGE	9A	
ELECTRIC CONSUMPTION	250W (AT.32°C, WT.21°C)	
POWER FACTOR	61%	
POWER SUPPLY CAPACITY	Min. 0.59kVA (2.5A)	
ICE PRODUCTION PER 24h	Approx. 27kg (5mm) / 30kg (15mm) (AT.10°C, WT.10°C)	
	Approx. 26kg (5mm) / 28kg (15mm) (AT.21°C, WT.15°C)	
	Approx. 22kg (5mm) / 25kg (15mm) (AT.32°C, WT.21°C)	
WATER CONSUMPTION PER 24h	Approx. 0.16m <sup>3</sup> (5mm)(AT.10°C, WT.10°C)	
	Approx. 0.07m <sup>3</sup> (5mm) (AT.21°C, WT.15°C)	
	Approx. 0.06m <sup>3</sup> (5mm) (AT.32°C, WT.21°C)	
SHAPE OF ICE	Cube Approx. 28×28×32mm	
FREEZE CYCLE TIME	21min (5mm) (AT.21°C, WT.15°C)	
ICE PRODUCTION PER CYCLE	0.4kg/18pcs.(5mm) (AT.21°C, WT.15°C)	
MAX STORAGE CAPACITY	12kg(Bin Control Setting Approx. 6kg)	
DIMENSIONS	398mm(W) × 510mm(D) × 695mm(H)	
EXTERIOR	Stainless Steel, Plastic Door & Louver, Galvanized Steel(Rear)	
INSULATION	Polyurethane Foam	
INSULATION FOAM BLOWING AGENT	Cyclopentane / CFC Free / ODP: 0 / GWP: 3	
CONNECTIONS-ELECTRIC	X-Type Connection	
CONNECTIONS-WATER SUPPLY	Inlet G1/2" (connected at rear side)	
CONNECTIONS-DRAIN	Outlet I.D. φ22mm (connected at rear side)	
ICE MAKING SYSTEM	Cell type	
HARVESTING SYSTEM	Hot Gas Defrost	
COMPRESSOR	Hermetic	
CONDENSER	Air-cooled	
HEAT REJECTION	520W 447kcal/h	
EVAPORATOR	Tin-plated Copper Tube on Sheet and Cells	
REFRIGERANT CONTROL	Capillary Tube	
REFRIGERANT CHARGE	R134a / 130g	
ICE MAKING CONTROL SYSTEM	Thermistor, Timer	Controller Board
HARVESTING CONTROL SYSTEM	Thermistor	
BIN CONTROL SYSTEM	Microswitch with Time Delay	
ICE MAKING WATER CONTROL SYSTEM	Timer, Water Pan's movement	
ELECTRICAL PROTECTION	Class I Appliance, 5A Fuse	
COMPRESSOR PROTECTION	Auto-reset Overload Protector	
ICE MAKER PROTECTION	Interlock by Controller Board	
WEIGHT	Net weight 39kg/Gross weight 49kg	
PACKAGE	Carton 490mm(W) × 610mm(D) × 880mm(H)	
ACCESSORIES	Scoop, Leg, Installation Kit	
OPERATING CONDITIONS	Ambient Temp.:1-40°C, Water Supply Temp.:5-35°C	
	Water Supply Pressure:0.07-0.78MPa(0.7-8bar) Voltage Range: Rated Voltage±6%	

■ We reserve the right to make changes in specifications and design without prior notice.

# HOSHIZAKI CUBE ICE MAKER IM-30CA

APPROVED KUROYANAGI	CHECKED MORIMOTO	DESIGNED KONDO	DRAWN WATANABE	SCALE 1/10	TRIGONOMETRY
*	*	△	*****	DATE 2013.11.06	DRAWING NO. D13640
APPROVED	DESIGNED	SYMBOL	DATE		SYMBOL △