

PLUG SHAPE

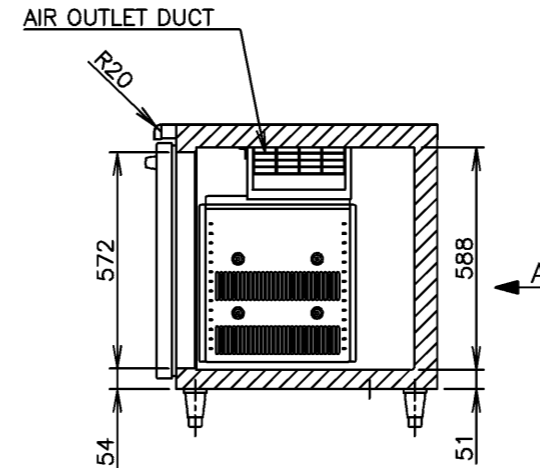
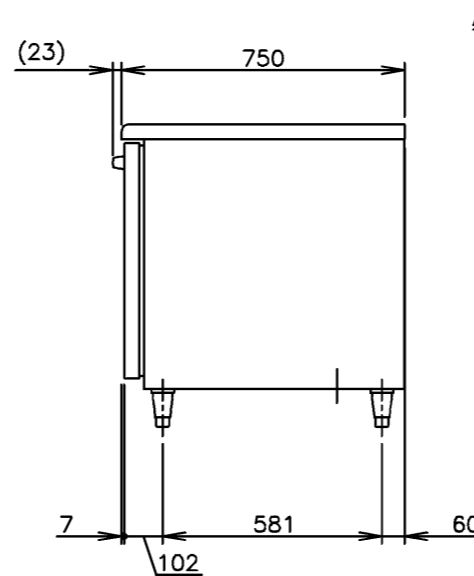
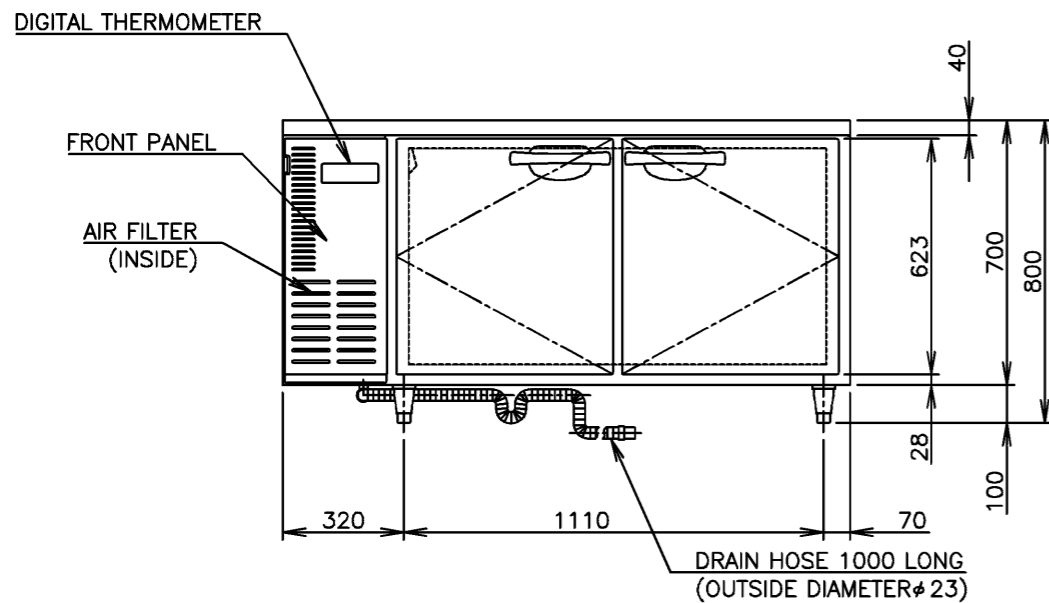
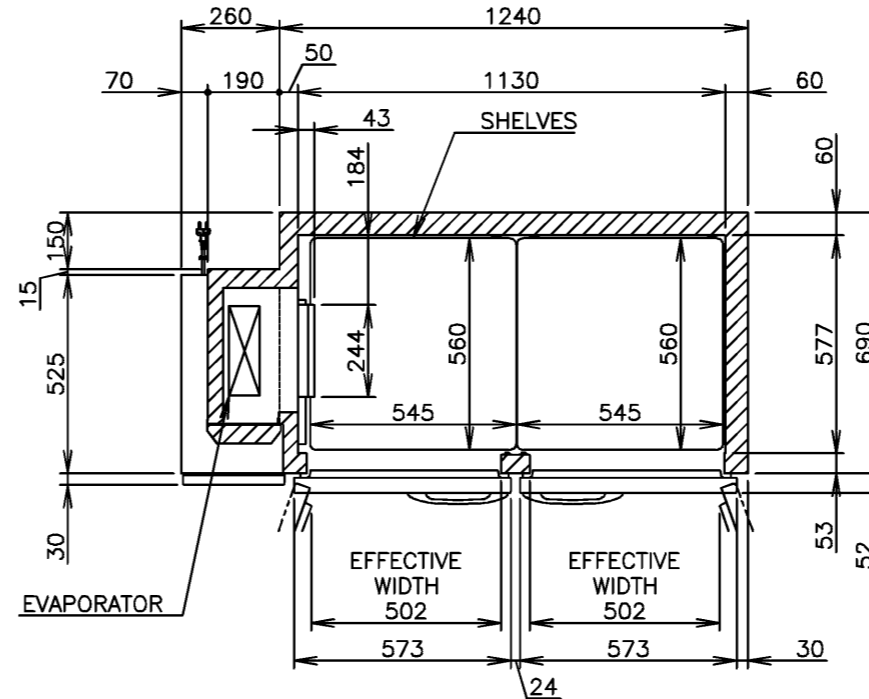
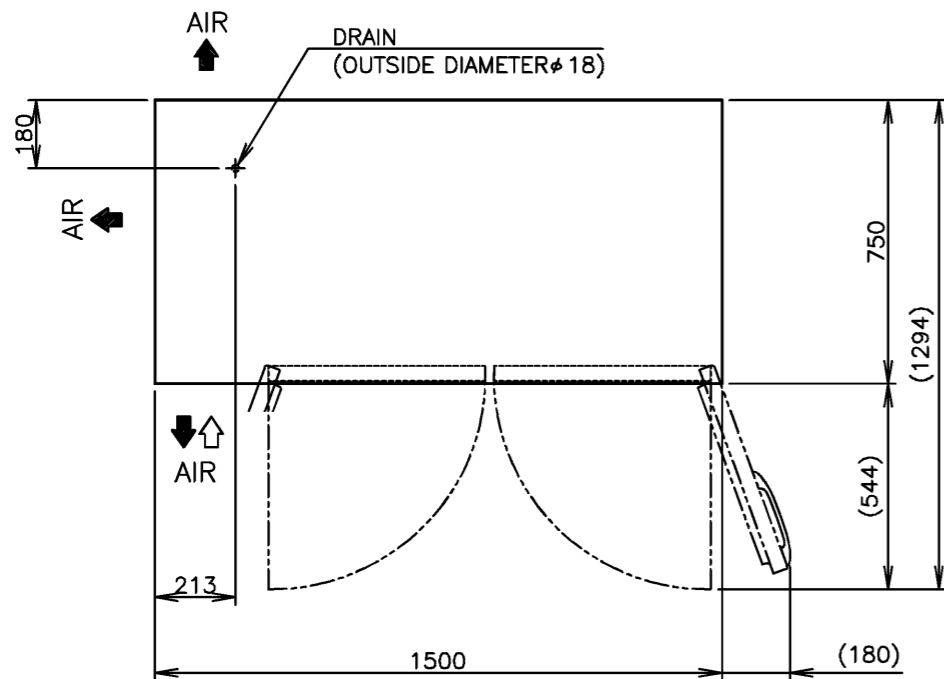

ITEM	Hoshizaki Undercounter Freezer
MODEL	FTC-150SDA
POWER SUPPLY	1 Phase 220-240V 50Hz Capacity:1.14kVA(5.18A)
AMPERAGE	Rated 3.2A Starting 18.6A
ELECTRIC CONSUMPTION	Motor 500W(Power Factor71%) Heater 373W Refrigeration 543W Defrost 373W
HEAT REJECTION	1070W
POWER CORD	2.8m (Plug with Earth Wire)
EFFECTIVE CAPACITY	413L
OUTSIDE DIMENSIONS	W1500×D750×H800(790-830)mm
INSIDE DIMENSIONS	W1130×D577×H588mm
EXTERIOR	Stainless Steel, Galvanized Steel (Rear/Bottom)
INTERIOR	Stainless Steel, ABS Plastic
INSULATION	Polyurethane Foam
REFRIGERATION SYSTEM	Forced Air Circulation Fan Motor DC12V 4W
DEFROST SYSTEM	Glass Tube Heater
COMPRESSOR	Hermetic 495W
CONDENSER	Fin and Tube type(8 tubes high 4 rows deep) Fan Motor 7W
EVAPORATOR	Fin and Tube Type(10 tubes high 3rows deep)
REFRIGERANT	R404A/190g
TEMPERATURE CONTROL	Microprocessor controlled Adjustable from -25 to -7℃
DEFROST CONTROL	Microprocessor controlled
ELECTRIC CIRCUIT PROTECTION	10A Fuse, Earth Wire
COMPRESSOR PROTECTION	Motor Protector
LEG	Plastic Adjustable from 90 to 130mm
WEIGHT	Net:105kg (Gross: Approx. 110kg)
PACKAGE	Carton W1565×D830×H790mm
ACCESSORIES	Drain Hose x 1(φ23mm OD), Cable strap x 3
OPERATING CONDITIONS	Ambient Temperature:5-43℃ Voltage Range:Rated Voltage±6%

1. Install the product properly in accordance with the instructions on location, electrical connections stated in the instruction manual provided. Allow 10mm extra space at the installation site to meet any installation requirements(additional spacing is also required for proper air flow).
2. The heat rejection is based on the reached pulldown temperature at ambient temperature of 43℃ and power supply of 220V 50Hz. The amperage and electric consumption are based on measurements at ambient temperature of 43℃ and power supply of 220V 50Hz.
3. The cabinet temperature range of -25 to -7℃ is guaranteed at ambient temperature of 30℃.

HOSHIZAKI UNDERCOUNTER FREEZER FTC-150SDA

APPROVED SAEKI	CHECKED FUJIHARA	DESIGNED KAWAKAMI	DRAWN KAWAKAMI	SCALE 1/20	TRIGONOMETRY
*	*	△	*****	DATE 2009.11.06	DRAWING NO. D05138
APPROVED	DESIGNED	SYMBOL	DATE		SYMBOL △