



Camshelving® GN 1/1 Food Pan Trolley

Full Size

Holds 18 each GN 1/1 Food Pans, 6,5 cm (2½") Deep

Half Size

Holds 9 each GN 1/1 Food Pans, 6,5 cm (2½") Deep

Features & Benefits

- Multi-purpose, end load trolley for holding, storing and transporting bulk food in GN food pans. Compact, slim design maximizes working space and storage space.
- Made from an extremely strong, revolutionary composite material with a smooth, easy to clean surface.
- Lifetime warranty against rust and corrosion.
- No metal parts, welds, screws, cross bars or metal casters than can break, bend, dent, rust or corrode.
- Moves easily between kitchen, freezer, cooler and/or off premise.
- Rails accept/hold hot pans from 200°C (392°F) oven.
- No marking or metal wipe from metal pans.
- Wide 7,6 cm (3") rail spacing offers greatest versatility and ease of use.
- Top frame features molded in supports to hold a single GN 1/1 Food Pan to cover and protect contents below. Convert the half size unit into a light duty workstation by placing a GN 1/1 cutting board on the top frame.
- Molded in lip load rails (food pan flange hangs from rails) for food pans.
- Molded in 3 mm (0.12") pan stops on each rail end help keep pans on the rails when turning or transporting.
- Food pan holding capacity:

	6,5 cm (2½")	10 cm (4")	15 cm (6")	20 cm (8")
Full Size Trolley				
1/1 Pans	18 each	9 each	9 each	6 each
1/2 Pans	36	18	18	12
1/3 Pans	54	36	36	18
Half Size Trolley				
1/1 Pans	9	4	4	3
1/2 Pans	18	8	8	6
1/3 Pans	27	12	12	9

- Weight bearing per rail set is 45 kg (100 lbs.). Unit weight bearing is 340 kg (750 lbs.).
- Four each heavy duty, 12,7 cm (5") premium plastic swivel casters all with total locking brake. Locks swivel and wheel. Non-marking thermoplastic rubber wheel. Rust and corrosion free.
- Easy to clean. Wipe down or pressure wash.
- Ships knockdown with casters and bottom frame wedges factory installed. Minimal assembly required.
- Components are easy to remove and replace if damaged, ensuring a lifetime of service.
- Optional accessories include Food Pans and Flat Covers. Full Size Vinyl Cover and Rail Pan Stop coming soon.
- Available in 1 color only – Speckled Gray (480).
- Patent pending.

Project _____

Item No. _____

Model No. _____

Quantity _____

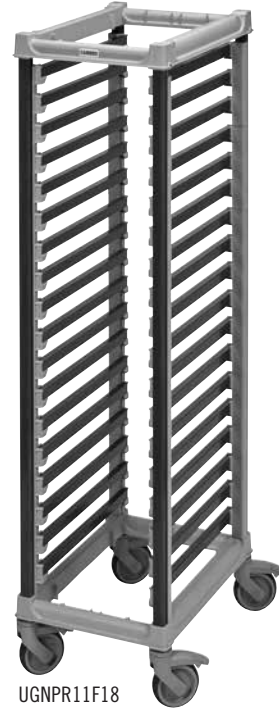

UGNPR11F18
Full Size Rack



UGNPR11H9
Half Size Rack

Approvals



COMPONENT

Information and specifications are subject to change without notice. Please confirm at time of order.



CAMBRO U.S.A.
TEL: 1(714) 848-1555
FAX: 1(714) 230-4375
international@cambro.com

CAMBRO EUROPEAN LOGISTICS
TEL: (49) 7022 90 100 0
FAX: (49) 7022 90 100 19
cambroeurope@cambro.com

CAMBRO UK
TEL: 0800 587 0057 Toll Free
FAX: 0845 280 3411
cambrouk@cambro.com

CAMBRO IRELAND
TEL: 1800 509 046 Toll Free
FAX: 01 633 55 76
cambroireland@cambro.com

© Copyright Cambro Manufacturing Company. Printed in the U.S.A. 07/20

Camshelving® GN 1/1 Food Pan Trolley

Project _____

Item No. _____

Model No. _____

Quantity _____

Full Size

Holds 18 each GN 1/1 Food Pans, 6,5 cm (2½") Deep

Half Size

Holds 9 each GN 1/1 Food Pans, 6,5 cm (2½") Deep

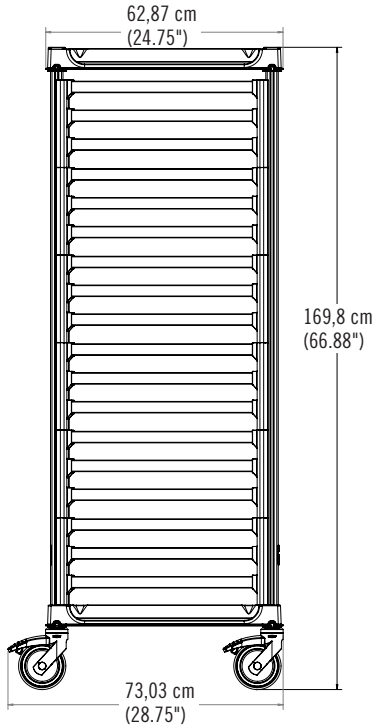

SIDE VIEW

UGNPR11F18

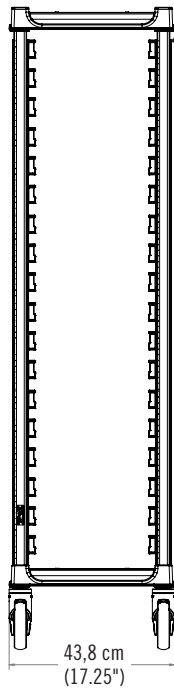

FRONT VIEW

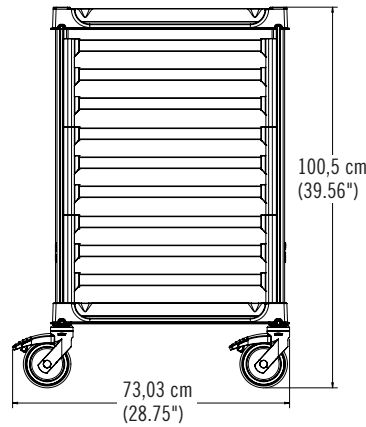
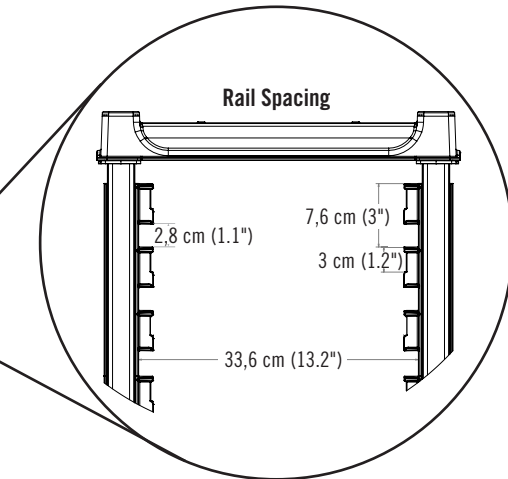

SIDE VIEW

UGNPR11H9

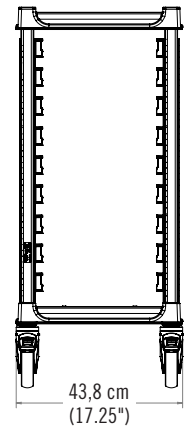

FRONT VIEW

Specifications

Dimension Tolerance: +/- 0,64 cm

Code	Description	Load Capacity	Dimensions L x W x H*	Unit Weight
UGNPR11F18	Full Size Trolley	340 kg (750 lbs.)	73,03 x 43,8 x 169,8 cm 28.75" x 17.25" x 66.88"	24,10 kg (53.15 lbs.)
UGNPR11H9	Half Size Trolley	340 kg (750 lbs.)	73,03 x 43,8 x 100,5 cm 28.75" x 17.25" x 39.56"	14,82 kg (32.68 lbs.)

* Includes 12,7 cm (5") Casters.

Architect Specs

Mobile Posts: Proprietary non-corrosive composite material. Post Connector Frames: Reinforced nylon. Side Rail Panels: Proprietary non-corrosive composite material and reinforced polypropylene. Post Connector Frame Wedges: Reinforced polypropylene. Casters: 12,7 cm (5"), plastic nylon frame, metal stem, non-marking thermoplastic wheel, with total locking brake. Units ship knockdown with casters and bottom post connector frame wedges factory assembled onto posts. Holds GN 1/1, 1/2 and 1/3 size food pans. Weight bearing per rail set is 45 kg. (100 lbs.). Unit weight bearing is 340 kg. (750 lbs.). Lifetime warranty against rust and corrosion. Unit color is Speckled Gray (480). Patent pending.

Standard Color

Speckled Gray (480)

Approvals



COMPONENT

Information and specifications are subject to change without notice. Please confirm at time of order.

CAMBRO
TRUSTED FOR GENERATIONS™
www.cambro.com

CAMBRO U.S.A.
TEL: (714) 848-1555
FAX: (714) 230-4375
international@cambro.com

CAMBRO EUROPEAN LOGISTICS
TEL: (49) 7022 90 100 0
FAX: (49) 7022 90 100 19
cambroeuropa@cambro.com

CAMBRO UK
TEL: 0800 587 0057 Toll Free
FAX: 0845 280 3411
cambrouk@cambro.com

CAMBRO IRELAND
TEL: 1800 509 046 Toll Free
FAX: 01 633 55 76
cambroireland@cambro.com

CSUGNPR1

© Copyright Cambro Manufacturing Company. Printed in the U.S.A. 07/20

1062004