



HOBART
**Food Preparation
Fast and Easy**

- ❑ Blends, mixes, stirs, whips, chops, mashes.
- ❑ Prepares paste, batter, dressings, herb oils, sauces, thickenings, mayonnaise, soups, desserts, milkshakes, cocktails, fruit drinks, juices, etc.
- ❑ For restaurants, bars, diet kitchens, hospitals, schools, fast-food outlets, the catering trade, supermarkets, etc.
- ❑ Generous jug, volume 4 litres and powerful, heavy-duty 1000 watt motor.

Blender FB-4

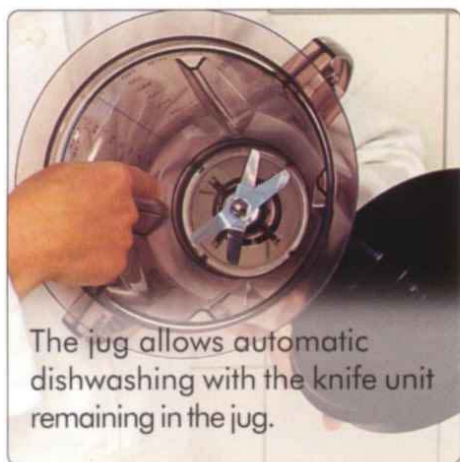

Hinged lid holder with safety switch function for fast opening/closing and safe use.



The jug allows automatic dishwashing with the knife unit remaining in the jug.



Low design for maximum stability and convenient filling/handling height.

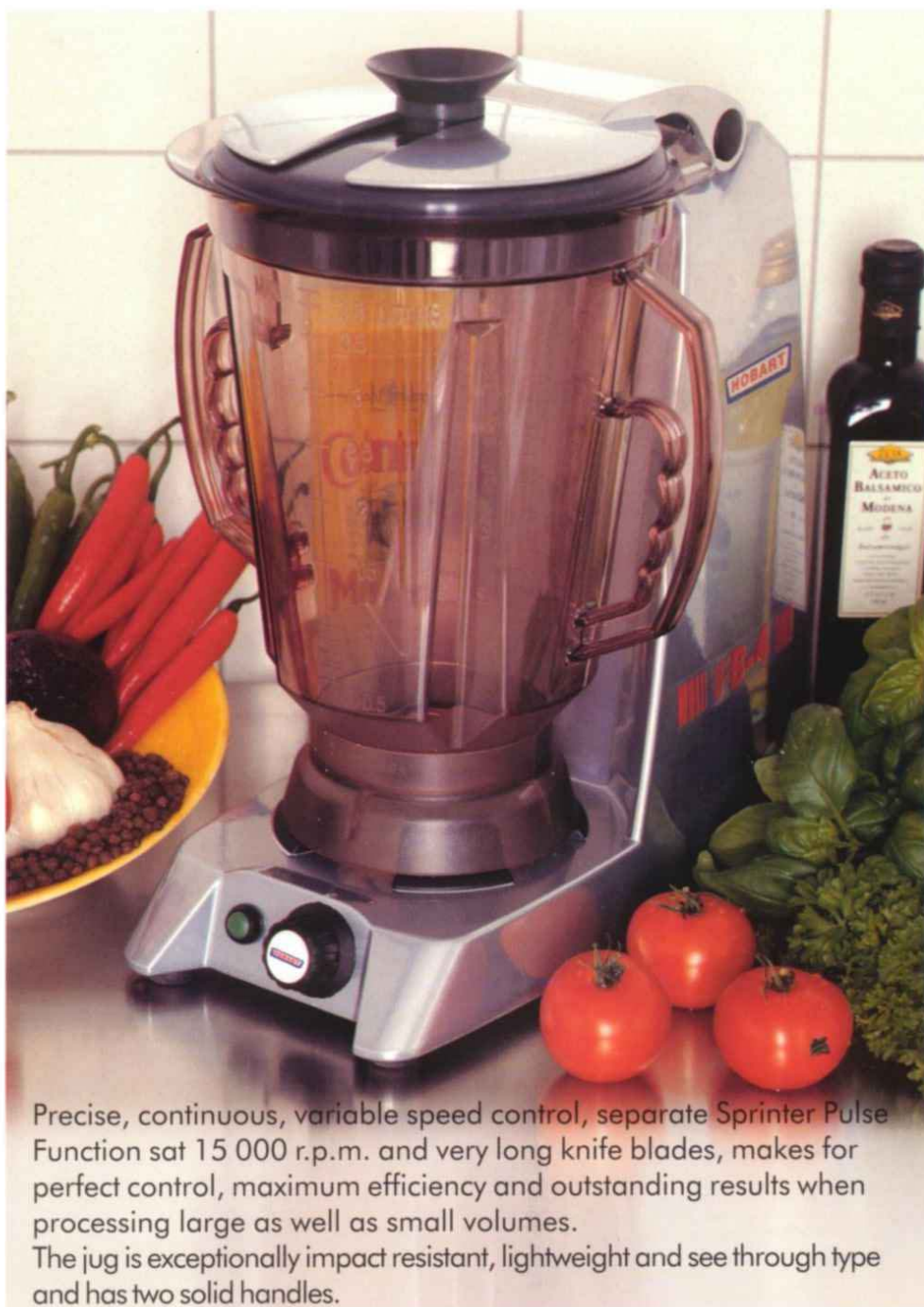

Precise, continuous, variable speed control, separate Sprinter Pulse Function sat 15 000 r.p.m. and very long knife blades, makes for perfect control, maximum efficiency and outstanding results when processing large as well as small volumes. The jug is exceptionally impact resistant, lightweight and see through type and has two solid handles.

HOBART Blender FB-4

Types of processing:

- Blends, mixes, whips, stirs, chops, mashes.
- Prepares paste, batter, dressings, herb oils, sauces, thickenings, mayonnaise, soups, desserts, milkshakes, cocktails, fruit drinks, juices, etc.

Users:

- Restaurants, bars, diet kitchens, hospitals, schools, fast-food outlets, the catering trade, supermarkets, etc.

Jug:

- Volume: 4 litres.
- Graduations: 0.5–3.8 litres, 10–140 ounces, 2–16 cups.
- Knife unit: extra long knife blades (72 mm from tip to tip), see MATERIALS.
- Lid: tight-fitting with filling hole (diameter 26 mm).
- Dosing feeder: volume 1 dl.
- The jug including the knife unit, the lid and the dosing feeder, can be machine washed without the need to remove the knife unit from the jug.

Machine base:

- Motor alternative 1: 1000 W, 220–240 V, single-phase, 50/60 Hz.
- Motor alternative 2: 1000 W, 110–120 V, single-phase, 50/60 Hz.
- Thermal motor protection with automatic reset.
- Fuse in the fuse box for the premises: 10 A, delayed.
- Electronic speed control for soft start and constant speed regardless of the load.
- Transmission: maintenance-free toothed belt.
- Safety system: mechanical safety switch.
- Degree of protection: IP34.
- Sound level LpA (EN31201): < 88 dB(A).

Speed controls:

- Speed setting knob for stepless, variable speed setting from 700 to 15 000 r.p.m.
- HOBART separate Sprinter Pulse Function button for direct access to maximum speed (15 000 r.p.m.) while the blender is operating.

Materials:

- Machine housing: aluminium alloy.
- Jug and dosing feeder: exclusiv, extremely impact-resistant and heat-resistant (115°) polysulfone.
- Lid: impact-resistant and heat-resistant (115°) polypropylene.
- Knife unit: blades of highest quality knife steel, maintenance-free stainless steel shaft, fully-encased and maintenance-free stainless steel ball-bearings.
- Drive coupling wheels on the jug and on the machine base: steel-reinforced acetal.

Net weights:

- Machine with lid: 5.7 kg.
- Jug: 0.9 kg.

Standards:

- EU Machinery Directive 89/392/EEC.

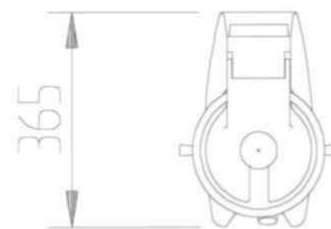
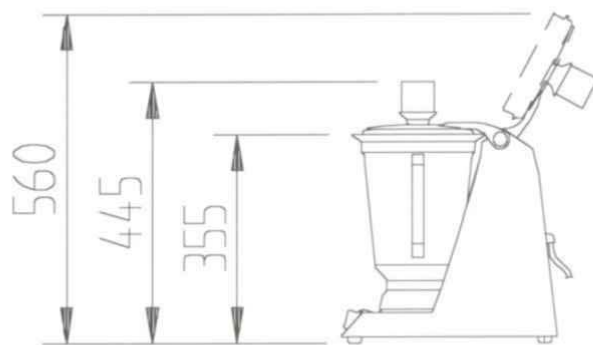
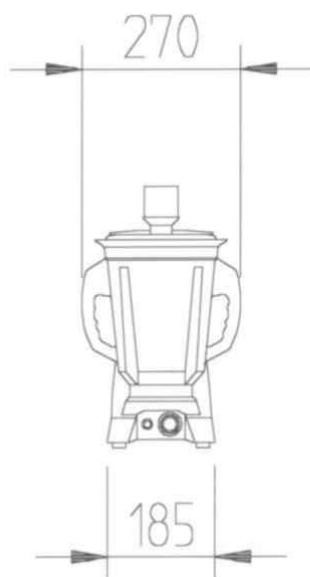

HOBART FOOD EQUIPMENT PTY LIMITED

16 Hilly Street,
Mortlake NSW 2137 Australia
PO Box 100, Concord NSW 2137
Telephone: (02) 9736 1200
Facsimile: (02) 9736 1555
Website: www.hobartfood.com.au
Offices in Adelaide, Brisbane, Melbourne and Perth



Solid equipment. Sound advice.